

HED[®]

Hydro Electronic Devices, Inc.

Realize Your Vision with Intelligent Control

Featuring the HED CanLink™ Control System

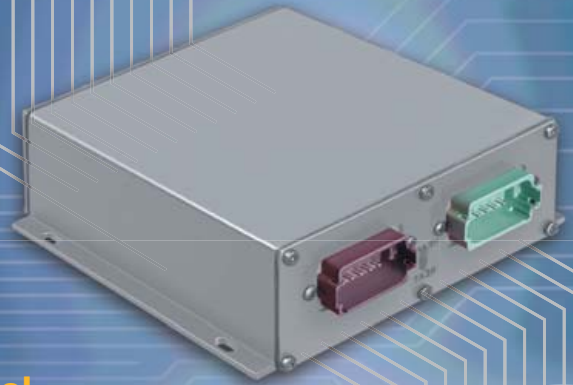



HED - The Controls Company

HED specializes in electronic control systems for mobile vehicles. Located in Hartford, Wisconsin, we provide all your electronic control requirements from single components through complete networked control systems. We operate as an extension of our customers' engineering department, providing support as needed to make their vision a reality.

What this Applications Guide is about.

Our customers are experts in their product lines: mobile vehicles for off-highway and on-highway use. Increasingly, mobile vehicles are designed to task-specific requirements involving complex functionality of transmissions and specialized tools. Electronic control systems can help those applications perform better, at lower cost, by eliminating complex wiring, mechanical linkages and hydraulic conduit. Helping engineers understand the promise and the potential of this technology is our core competency!

This guide is a quick look at what's available, what's possible, and how HED can make it happen.

The Medtec ambulance is equipped with an advanced electrical system that puts a wide range of data at the fingertips of personnel throughout the vehicle.



Electronic Controls

Complex machines require complex controls. Control systems that use traditional hydraulic conduit and mechanical linkages can quickly get out-of-hand. Electronics offer a way to simplify control while actually offering greater precision for specific tasks. Benefits include:

■ **Simplicity**

Instead of routing hydraulic conduit to the operator station and then to the tool, hydraulics only need to go from the power source to the tool. This allows for a smaller, easier-to-use operator station and cost savings, especially when the operator is located some distance from the tool.

■ **Reliability / Ergonomics**

Leak-prone hydraulics are minimized and replaced with shock-resistant, ruggedized electronics. Electronic input devices are smaller, require less operator effort, and generate less heat, increasing cab space and comfort and reducing operator fatigue.

■ **Intelligence/Safety**

You can prevent dangerous situations with safety interlock logic, activate alarms and involve multiple vehicle systems simultaneously to perform a specialized task. Solid state electronics eliminate relay logic and fuses, while enhancing safety and performance by optimizing simultaneous operation of multiple vehicle functions.

■ **Extended Component Life**

By controlling transmission shift patterns, component duty cycles, and programming "soft limits" when components near their maximum range, electronic control minimizes wear and tear and abusive vehicle operation, thus maximizing service life.

■ **Programmable**

HED offers customers the option to use Windows-compatible software to create, adjust or completely re-engineer the control programming. This gives the customer ultimate control over vehicle function, and allows infinite opportunities for differentiation of a single basic design.

■ **Faster New Product Development (NPD) Timelines**

Engineers can move from drawing board to prototype and production more quickly when electronics are involved. Hardware components can be tested and validated along with overall vehicle design, with control systems moving on a parallel path. That allows engineers to quickly exploit windows of opportunity, and use a basic vehicle design for multiple purposes with different add-on accessories.

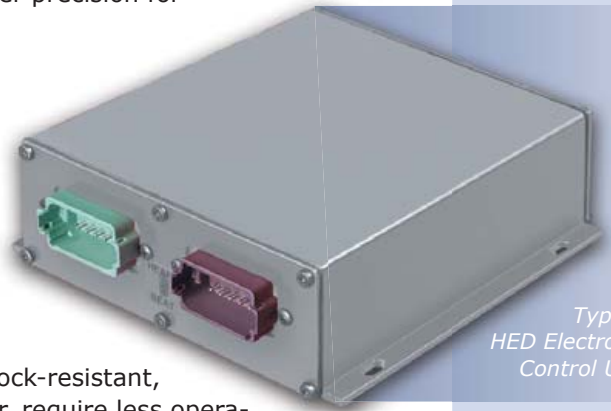

*Typical
HED Electronic
Control Unit*

Multiplexing

Even though electronic controls tend to be simpler than hydraulic or mechanical linkage controls, the number of wires involved can quickly add up. Multiplexing allows control of multiple functions through a single pair of wires, eliminating the need for complex wiring harnesses.

Multiplexing allows you to distribute electronic control judiciously to various quadrants or input/output concentration areas on your vehicle, coordinating electronic sensors and operator inputs with output devices and actuators using computer logic.

Systems with 2, 22, or more nodes can dramatically reduce wiring complexity by placing control modules close to sensor inputs and control devices, connecting modules through the CAN bus.

Multiplexing

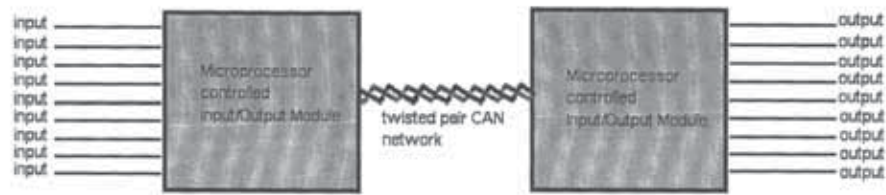

J-1939

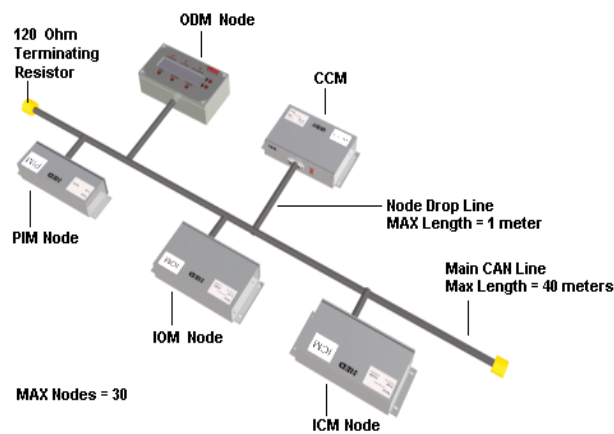

HED is experienced at designing control systems that make use of multiplexing, and offers its own line of components, CANLink™, which is fully compatible with the J-1939, CANopen, DeviceNet, or customer-specific communications protocols, to name just a few.

■ Engine Control

Communications with Engine Control Modules (ECM), enables task-based control of engine operating/idle speed. In addition, you can monitor engine conditions (overheating, transmission status, etc) from the operator station and automatically control vehicle load conditions to prevent engine stall.

■ Multi-Station Control

Multiplexing simplifies control of vehicle or tool operation from multiple points on the vehicle: from the operator's cab, from a station near the tool, or even remotely (off-vehicle) through a wired or wireless connection.

■ Self-diagnosis and reporting

Multiplexing simplifies the hardware / software interface and makes it easier to locate problems and alert operators. In addition to built-in diagnostic capabilities, HED multiplexing can check the entire network from a single module, using Windows-based software.

■ The bottom line

HED multiplexing, the CANLink™ system, is designed for survivability under extreme and hostile environments. Multiplexing means lower costs, fewer wires to break, faster speed-to-market and simplified troubleshooting in the field. Plus, the HED CANLink™ products offer maximum protection from high EMI/RFI exposure, extreme vibration and temperatures, dirt, dust, moisture and hard equipment wash-downs.



More and easier to read information is available to operators through graphical displays, and cab display and instrument cluster wiring is reduced by multiplexing.

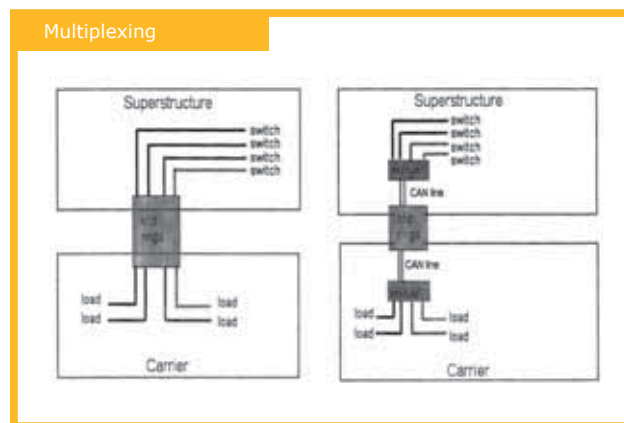

Multiplexing allows for complex vehicle design while minimizing the need for slip rings



Typical multiplexing applications on a mobile vehicle

These are places where you will find HED CANLink™ components:

Power System

Typical inputs: resistive, pressure and temperature sensors, speed pickups and electronic engine or transmission communications.

Typical outputs: servo valve pump control, starter solenoids, throttle servos, and electronic engine or transmission communications.

- Access vehicle ECM
- Log data for maintenance and troubleshooting
- Match power curve to specific vocational requirements

Valve Banks

Typical inputs: resistive, pressure and temperature sensors.

Typical outputs: servo valve pump control, proportional valves, on/off valves.

- Reduce leak-prone hydraulic connections, cut costs
- Add proportional PWM controls for improved performance

Remotes and Communication

Typical inputs: modem connections, GPS inputs and remote controls.

- Allows remote control of any multiplexed function
- Wired or wireless operation, on-vehicle or off-vehicle
- Allows fast and even remote access to vehicle diagnostics and maintenance records for simplified fleet management

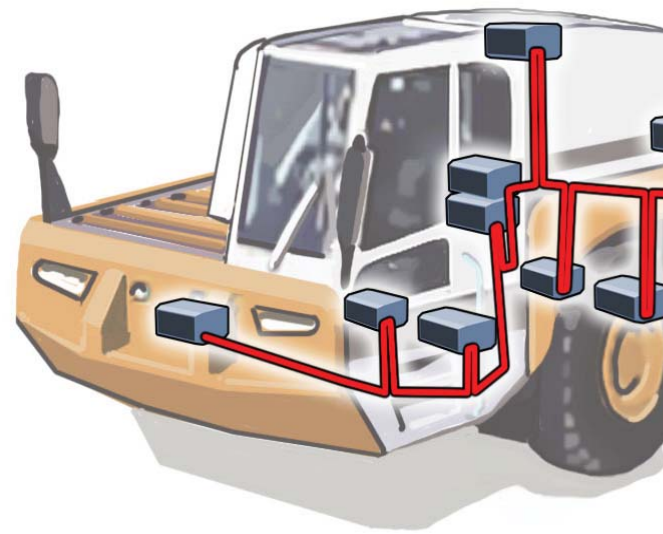

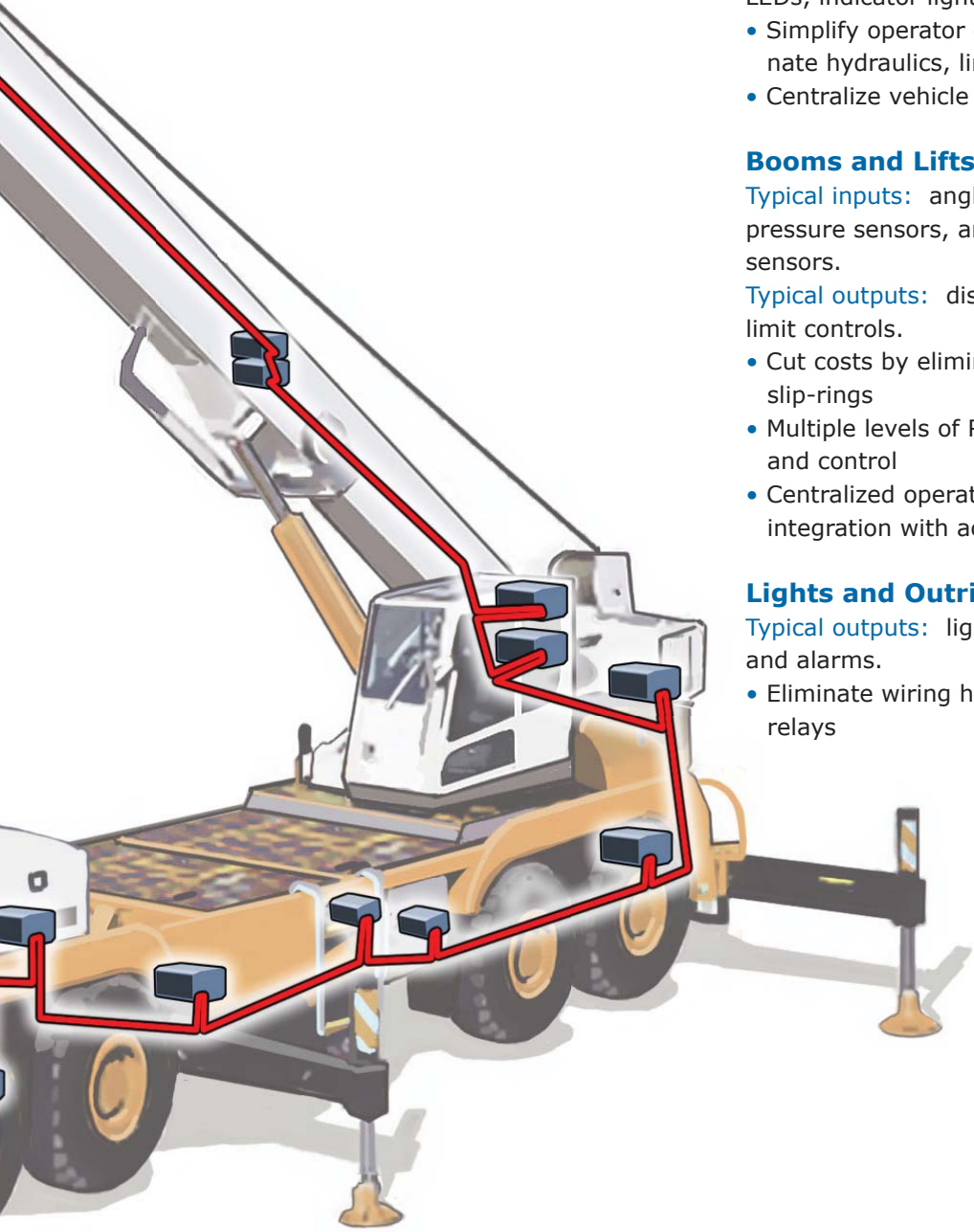

Console/Dash

Typical Inputs: joysticks, dash switches, potentiometers, operator presence switches.

Typical Outputs: gauges, displays, LEDs, indicator lights, alarms.

- Simplify operator controls, eliminate hydraulics, linkages
- Centralize vehicle data and controls

Booms and Lifts

Typical inputs: angle sensors, pressure sensors, and position sensors.

Typical outputs: displays, alarms, limit controls.

- Cut costs by eliminating multiple slip-rings
- Multiple levels of RCL/LMI safety and control
- Centralized operator display, integration with actuators

Lights and Outriggers

Typical outputs: lights, valves, relays and alarms.

- Eliminate wiring harnesses and relays

Vehicle Applications

CAN Multiplexing Offers Increased Performance, Added Flexibility, Reduced Development Time, and Lower Lifetime Vehicle Ownership Cost

- Reduce wiring complexity and cost
- Easily add production or aftermarket options while keeping base unit cost low
- Quickly introduce new vehicle features with little or no hardware modifications
- Locate I/O modules close to the source
- Simplify vehicle troubleshooting

■ Fire Aerial Ladder Application

The number of wires exiting a fire truck cab can number in the hundreds without the use of CAN multiplexing technology. The reduction in vehicle wiring cost and field service troubleshooting time alone can easily pay for the cost of the multiplexing system.

■ Aerial Work Platform Application

For aerial work platform applications, multiplexing can easily accommodate multiple operator stations in the platform or on the ground, using wired or wireless remote controls. The system could control platform rotation, hydrostatic transmission and as well as outrigger operation, including safety interlock logic to prevent dangerous operating conditions while providing smooth, precise work platform positioning. Simplified wiring can also reduce the amount of slip rings required to route control circuitry through the swing drive.

Platform control can be accomplished easily using multiplex wiring through the boom or wireless control modules.

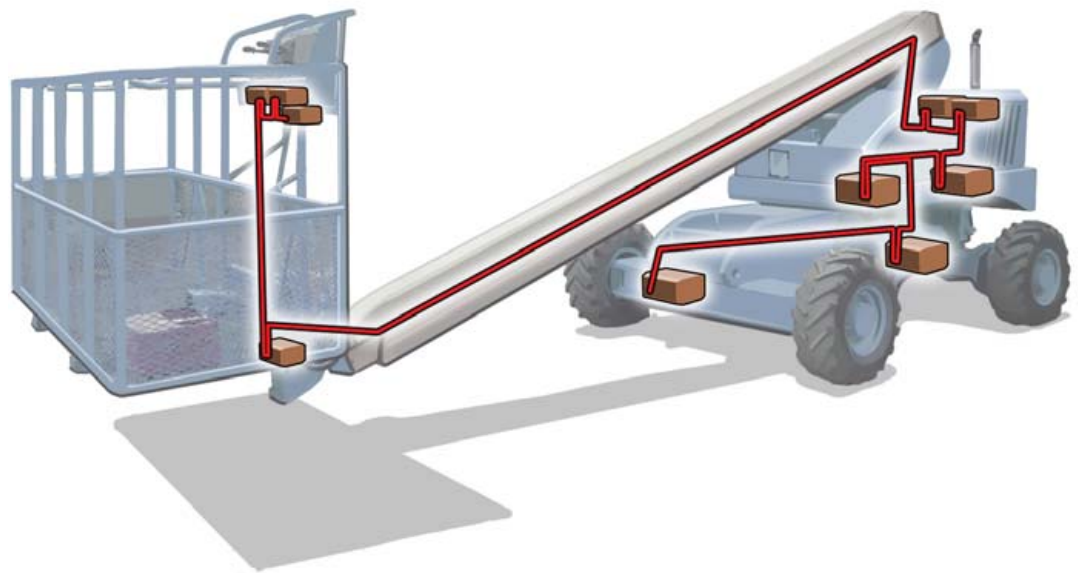

Vehicle Applications

■ Road Building Machine

Road building vehicles such as recyclers and skid-steer loaders are often offered with a multitude of variations or attachments. Multiplexing systems allow the pre-wiring for these options for addition of control module hardware only as needed to implement the options. The software for additional options can be included on the base unit and options or attachments can be automatically recognized when added on the production line or by the dealer or end user. The use of identification pins in the wiring harness can also allow identical control modules to function completely differently depending on where it is mounted on the vehicle and what job it is required to do in that location.

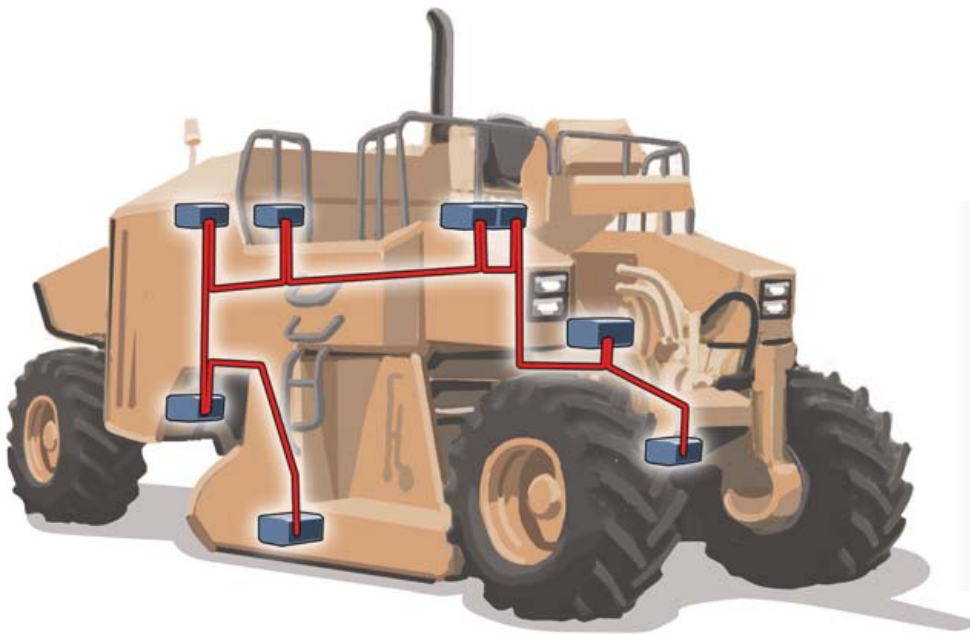

Graphical displays in the cab provide operating data, diagnostics, and even video input from cameras used for vehicle positioning.

Windows-based programming expands the capabilities of CANLink™

CANLink™ modules can be programmed at HED and shipped ready for your single application, or they may be programmed by your own design team. This allows designers to give vehicles different performance characteristics for different applications without changing the basic production hardware components. The benefits include simplified design, reduced inventory and the ability to quickly deliver customer-specific products.

■ Do-It-Yourself Windows-Based Software Programming Tool CANLink™ Composer

This easy-to-use software requires no programming language knowledge to generate complete vehicle control programs. Whether your system uses a single stand alone module or a multiplex system, you can create new or modify existing control programming as dictated by your customer requirements, providing you with greater control, flexibility, and responsiveness. The program uses simple ladder logic to construct even the most complex functions, and a complete contextual help function is available at every step.

Do-It-Yourself programming tool is easy to use. Windows-based, and places electronic vehicle control at your command.

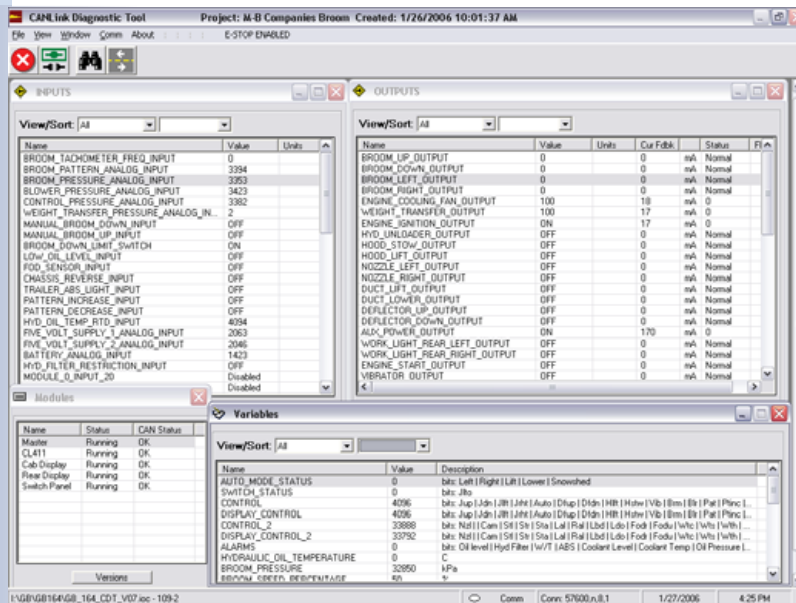



■ Diagnostic Tool for On-Board or Remote Troubleshooting

CANLink™ Conductor

A powerful tool to identify and troubleshoot vehicle performance issues or electrical circuit faults. Pinpoints errors and dramatically reduces troubleshooting and wire tracing time for fast, reliable customer service. Unique real-time “Debug” feature allows service technician to bypass normal control logic and force operation of inputs and outputs to help identify the source of system faults. Available in read-only and full functional versions.

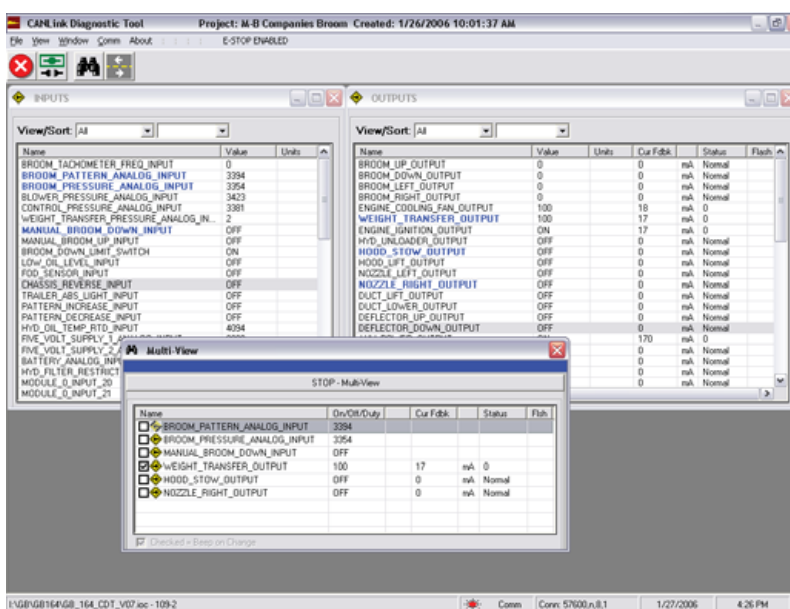

Improve your customer service by diagnosing programming logic, system faults, and troubleshooting a vehicle on site with CANLink™ Conductor.

■ Device Calibration Tool

CANLink™ Tuner

This convenient tool allows calibration of signal ranges for individual proportional inputs and outputs on your vehicle for smoother, more precise control performance. Whether for installing input or output devices at the end of the production line or for service replacements in the field, your control programming can adjust for sensor or actuator signal range tolerances.

HED is located in Hartford, Wisconsin, and provides a total subsystem

solution: Engineering is provided by our own staff of highly-qualified engineers with years of experience working on many applications. We maintain an ever-growing library of circuit designs and software programs, for cost-effective custom and semi-custom product offerings. Manufacturing is completed in our own ISO 9000-2001 certified facility. We also provide field service and rebuilding.



Hydro Electronic Devices, Inc.

1715A Innovation Way
Hartford, Wisconsin 53027
(262) 673-9450
Toll Free 800 398-2224
Fax (262) 673-9455
www.hedonline.com

e-mail: info@hedonline.com

Need Form Number



© date
Production code for document