

CANLink[®] CL-103-1XX Module Family Master Control Module



Special Features include:

- (3) J1939 CAN ports
- (2) RS232 ports
- (1) J1708 port
- (1) USB port
- (2) switch to ground inputs
- (1) 0.5A PWM output
- Battery voltage monitoring

The CL-103 is a solid-state microprocessor based module and member of the HED[®] CANLink[®] multiplexed control family. Delivered in a Deutsch enclosure, this unit provides powerful functionality in a compact and economical package.

Designed as a master control module, the CL-103 includes 4 different communications ports (7 Total). Three J1939 and one J1708 CAN ports enable the module to perform a dual role as a master controller and communications bridge between multiple CAN systems on one vehicle.

The HED[®] CL-103 can be programmed using HED[®]'s do-it-yourself CANLink[®] Composer[™] programming tool or directly by HED[®] engineering, and is designed for use with the CANLink[®] Conductor[™] software tool for diagnostics and field troubleshooting.

Specifications

Enclosure:	Deutsch standard EEC-325x4 PCB enclosure with 24-pin receptacle.
Connectors:	DTM06-12SA DTM06-12SB WM-12S (wedge) – Two needed (one per connector) 0462-201-20141 20AWG sockets 0413-204-2005 Sealing Plugs – Unused pins are required to be sealed to maintain module sealing
Operating Voltage Range:	8 to 32 VDC
Operating Temperature:	-40°C to 70°C
Storage Temperature:	-40°C to 85°C
IP Rating:	IP 6K9K
PC Boards:	The printed circuit boards designed for high EMI/RFI protection. The boards are conformal coated with a silicone coating for further water/moisture protection. All inputs are protected against shorts to Battery(+) or Battery(-). 100% of the boards are functionally tested before shipment. * Harness codes are switch to ground inputs used to identify I/O module location and function to the master controller

CL-103 Master Control Module

CL-103 Master Control Module Pinout

DTM13-12PA (Gray)		DTM13-12PB (Black)	
Pin	Function	Pin	Function
1	Unused	1	Input Unswitched BAT(+)**
2	USB (DP)	2	Output DOUT(+)/PWM(+)(0.5A)
3	USB (DM)	3	CAN/J1708 (Shield)
4	USB/RS232 (GND)	4	RS232-2 (Tx)
5	RS232-1 (Tx)	5	RS232-2 (Rx)
6	RS232-1 (Rx)	6	RS232 (GND)
7	CAN2-L	7	J1708-A
8	CAN2-H	8	J1708-B
9	CAN1-L	9	CAN3-L
10	CAN1-H	10	CAN3-H
11	BAT(-) Module	11	Input STG
12	BAT(+) Module / Input Battery Voltage	12	Input STG

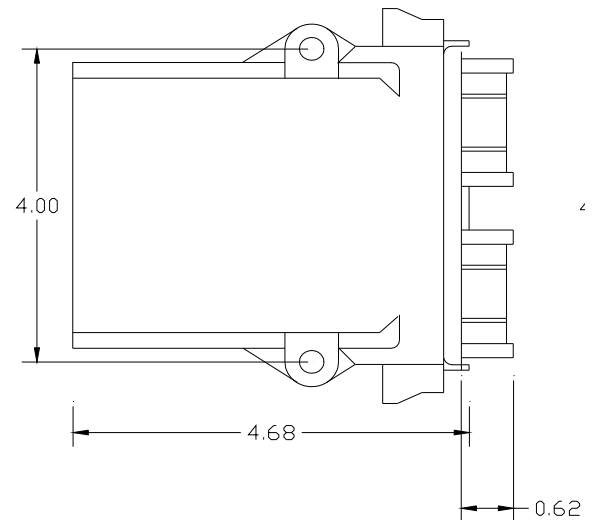

Note: Different I/O combinations are available. Please refer to specific CL-103-1XX data sheet for I/O number designations for use within Composer™. Data sheets available on HED® website.

**Unswitched vehicle battery must be connected to properly store data to EEPROM. Module will draw max of 200 micro amps (12V) and 400 micro amps (24V) after turning itself off.

