

CANLink® CL-416-100 Module I/O Module (24V)



8 Inputs and 8 Outputs including:

- (4) inputs software configurable as switch to battery or 0-5.5VDC 10-bit analog
- (2) inputs software configurable as switch to ground or 0-5.5VDC 10-bit analog
- (2) inputs software configurable as switch to ground or 0-35VDC 10-bit analog
- (4) harness codes* inputs
- (8) 500mA sinking PWM outputs (with 10K pull-up resistors to +Battery)
- (1) J1939 CAN Input

The CL-416 is a solid-state microprocessor based module and member of the HED® CANLink® multiplexed control family. Delivered in a Deutsch enclosure, this unit provides a high density I/O count in a compact and economical package.

Designed for use as a stand alone unit or as part of a distributed system, the CL-416 is also available in a clear enclosure with LED indicators for each input or output for simple troubleshooting in the field.

The HED® CL-416 can be programmed using HED®'s do-it-yourself CANLink® Composer™ programming tool or directly by HED® engineering, and is designed for use with the CANLink® Conductor™ software tool for diagnostics and field troubleshooting.

Specifications

Enclosure:	Deutsch standard EEC-325x4 PCB enclosure with 24-pin receptacle.
Mating Connectors: Deutsch	DTM06-12SA DTM06-12SB WM-12S (wedge) – Two needed (one per connector) 0462-201-20141 20AWG sockets 0413-204-2005 Sealing Plugs – Unused pins are required to be sealed to maintain module sealing
Operating Voltage Range:	18-32 VDC
Operating Temperature:	-40°C to 70°C
Storage temperature:	-40°C to 85°C
IP Rating:	IP 6K9K
PC Boards:	The printed circuit boards are designed for high EMI/RFI protection. The boards are conformal coated with a silicone coating for further water/moisture protection. All inputs and outputs are protected against shorts to Battery(+) or Battery(-). 100% of the boards are functionally tested before shipment. * Harness codes are switch to ground inputs used to identify I/O module location and function to the master controller

CL-416-100 I/O Module

CL-416-100 I/O Module Pinout

Pin	Function	Pin	Function
1	Input #1 STB/AIN(0-5.5V)	1	Output #1 DOUT(-)/PWM(-)(0.5A)
2	Input #2 STB/AIN(0-5.5V)	2	Output #2 DOUT(-)/PWM(-)(0.5A)
3	Input #3 STB/AIN(0-5.5V)	3	Output #3 DOUT(-)/PWM(-)(0.5A)
4	Input #4 STB/AIN(0-5.5V)	4	Output #4 DOUT(-)/PWM(-)(0.5A)
5	Input #5 STG/AIN(0-5.5V)	5	Output #5 DOUT(-)/PWM(-)(0.5A)
6	Input #6 STG/AIN(0-5.5V)	6	Output #6 DOUT(-)/PWM(-)(0.5A)
7	Input #7 STG/AIN(0-35V)	7	Output #7 DOUT(-)/PWM(-)(0.5A)
8	Input #8 STG/AIN(0-35V)	8	Output #8 DOUT(-)/PWM(-)(0.5A)
9	CAN-L	9	HID#1
10	CAN-H	10	HID#2
11	BAT(-) Module	11	HID#3
12	BAT(+) Module	12	HID#4

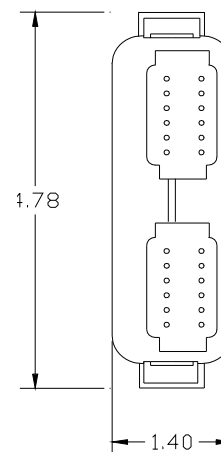
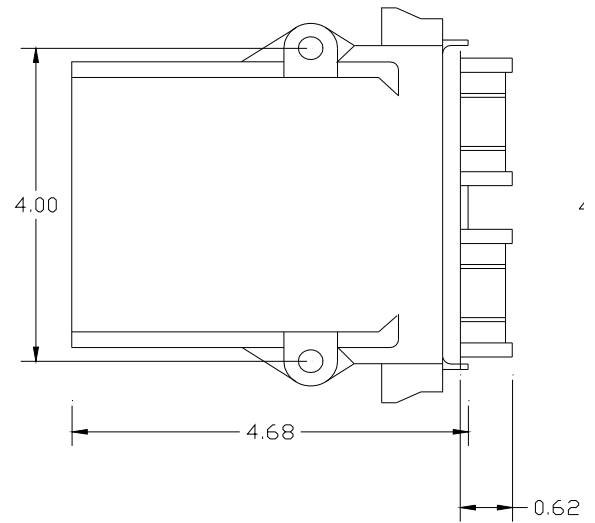

Note: Above pinout is for HED[®] part number CL-416-100.
Additional part number data sheets available on HED[®] website.