

CANLink® CL-422-1XX Module Family I/O Module



Representative Product Photo

The CL-422 is a solid-state microprocessor based module and member of the HED® CANLink® multiplexed control family. Delivered in an aluminum enclosure, this unit provides a large and highly flexible I/O count in a compact package.

The CL-422 is designed for use as a multi-purpose stand alone unit or as a master controller in a distributed system.

The HED® CL-422 can be programmed using HED®'s do-it-yourself CANLink® Composer™ programming tool or directly by HED® engineering, and is designed for use with the CANLink® Conductor™ software tool for diagnostics and field troubleshooting.

29 Inputs and 24 Outputs including:

- (16) switch to battery inputs
- (8) inputs hardware configurable as switch to battery or 12-bit analog
- (2) inputs software configurable as switch to ground, frequency² or harness code¹
- (2) inputs hardware configurable as switch to ground, 10-bit analog or harness code¹
- (1) 10-bit analog input
- (8) 2A PWM outputs with 2-wire current feedback
- (2) 2A PWM³ outputs
- (12) 2A digital outputs
- (2) 2A outputs configurable as:
 - (2) PWM³ and (0) digital outputs, (0) frequency inputs²
 - (1) PWM³ and (1) digital outputs, (1) frequency inputs²
 - (0) PWM³ and (2) digital outputs, (2) frequency inputs²
- (1) 5VDC regulated sensor supply (50mA) or 10-bit analog input
- (2) J1939 CAN ports
- (1) RS232

Specifications	
Enclosure:	Aluminum Extrusion
Mating Connectors: Deutsch	Deutsch DRC16-40SA Deutsch DRC16-40SB 0462-201-20141 20AWG sockets 0462-201-16141 16AWG sockets
Operating Voltage Range:	8 to 32 VDC
Operating Temperature:	-40°C to 85°C
Storage Temperature:	-40°C to 85°C
IP Rating:	IP 67
PC Boards:	The printed circuit boards are designed for high EMI/RFI protection. The boards are conformal coated with a silicone coating for further water/moisture protection. All inputs and outputs are protected against shorts to Battery(+) or Battery(-). 100% of the boards are functionally tested before shipment.
<ol style="list-style-type: none"> 1. Harness codes are switch to ground inputs used to identify I/O module location and function to the master controller. 2. Number of frequency inputs capable depends on output configuration. 3. Flyback suppression utilizes zener diode not standard diode, so energy will be clamped much faster. Customer will need to verify proportional valve will function properly with zener diode. 	

CL-422 I/O Module

CL-422 I/O Module Pinout

DRC13-40PB 40-Pin Connector		DRC13-40PA 40-Pin Connector	
Pin	Function	Pin	Function
1	Output DOUT(+)/PWM(+)/CC(+)(2A)	1	BAT(+) Module and Sensor Supply / Input Battery Voltage
2	Output DOUT(+)/PWM(+)/CC(+)(2A)	2	Output DOUT(+)/PWM(+)(2A)
3	Output DOUT(+)/PWM(+)/CC(+)(2A)	3	Output DOUT(+)/PWM(+)(2A)
4	Output DOUT(+)/PWM(+)/CC(+)(2A)	4	Output DOUT(+)/PWM(+)(2A)
5	BAT(+) Outputs	5	Output DOUT(+)/PWM(+)(2A)
6	Output DOUT(+)/PWM(+)/CC(+)(2A)	6	BAT(+) Outputs
7	Output DOUT(+)/PWM(+)/CC(+)(2A)	7	Output DOUT(+)(2A)
8	Output DOUT(+)/PWM(+)/CC(+)(2A)	8	Output DOUT(+)(2A)
9	Output DOUT(+)/PWM(+)/CC(+)(2A)	9	Output DOUT(+)(2A)
10	BAT(-) Outputs	10	Output DOUT(+)(2A)
11	CC Return	11	BAT(-) Module
12	CC Return	12	Output DOUT(+)(2A)
13	CC Return	13	Output DOUT(+)(2A)
14	CC Return	14	Output DOUT(+)(2A)
15	Unused	15	Output DOUT(+)(2A)
16	CC Return	16	BAT(+) Outputs
17	CC Return	17	Output DOUT(+)(2A)
18	CC Return	18	Output DOUT(+)(2A)
19	CC Return	19	Output DOUT(+)(2A)
20	BAT(+) Module and Sensor Supply / Input Battery Voltage	20	Output DOUT(+)(2A)
21	Input STB	21	5VDC Sensor Supply (50mA) / Input Sensor Supply Voltage or AIN
22	Input STB	22	Input STB/AIN
23	Input STB	23	Input STB/AIN
24	Input STB	24	Input STB/AIN
25	Input STB	25	Input STB/AIN
26	Input STB	26	Input STB/AIN
27	Input STB	27	Input STB/AIN
28	Input STB	28	Input STB/AIN
29	Input STB	29	Input STB/AIN
30	BAT(-) Module	30	5V Sensor Ground
31	Input STB	31	Input AIN/Unswitched BAT(+)*
32	Input STB	32	Input HID/STG/FREQ
33	Input STB	33	Input HID/STG/FREQ
34	Input STB	34	Input HID/STG/AIN
35	Input STB	35	Input HID/STG/AIN
36	Input STB	36	RS232 (TX)
37	Input STB	37	RS232 (RX)
38	CAN (Shield)	38	RS232 (GND)
39	CAN2-L	39	CAN1-L
40	CAN2-H	40	CAN1-H

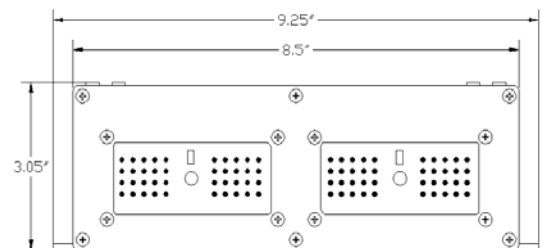
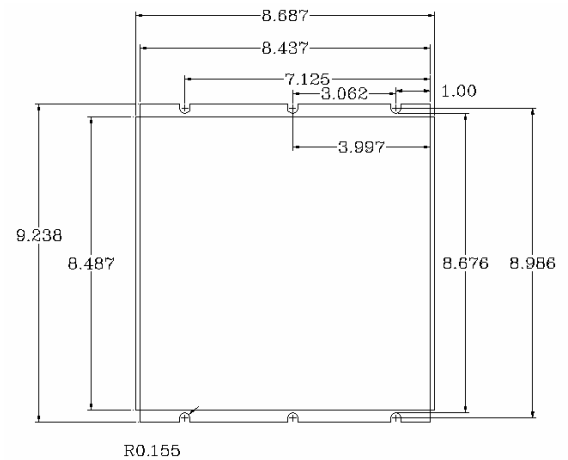

Note: Different I/O combinations are available. Please refer to specific CL-422-1XX data sheet for I/O number designations for use within Composer™. Data sheets available on HED® website.

*Unswitched vehicle battery must be connected to properly store data to EEPROM. Module will draw max of 200 micro amps (12V) and 400 micro amps (24V) after turning itself off. This feature is only available on versions of this module that are Master Module capable.