



NFPA

Solutions through motion technology

3333 N. Mayfair Road • Milwaukee, WI 53222-3219 • +1 414-778-3344

Technical Paper Series

I00-15.5

Using J-1939 CAN Systems on Heavy Equipment with Electrohydraulics and Why

Edward T. Heck, Hydro Electronic Devices, Inc. (HED®)

Tony Caravella, Hydro Electronic Devices, Inc. (HED®)

Presented at the International Exposition for Power Transmission
and Technical Conference
4-6 April 2000

USING J-1939 CAN SYSTEMS ON HEAVY EQUIPMENT WITH ELECTROHYDRAULICS AND WHY

Edward T. Heck, HED (Hydro Electronic Devices, Inc.), Hartford, WI

Abstract

The use of SAE standard J-1939 for Controller Area Networks (CAN) is rapidly growing on heavy duty On-Highway and Off-Highway Machines. Most of these machines are incorporating electro-hydraulic controls. Before the design engineer is stampeded into CAN for CAN's sake, he should know when and why to use CAN and when to can CAN.

CAN is designed to provide the ability to apply a number of microprocessor based controls to a machine and have them all talk to each other. It is an extremely cost effective way to control complex machines. It not only is capable of replacing today's centralized control schemes; but, is capable of doing the replacement cost effectively while offering additional benefits that have not been cost effective with older designs.

The use of "Registered" and "Proprietary" J-1939 systems will be discussed. When to use each and what the impacts of each type are is important to the designer. A summary of where CAN J-1939 is today and where it is going will allow the designer to make intelligent decisions. Applications will be used to illustrate both good and bad applications.

The paper will conclude with a discussion of the items to watch for in order to be sure that the CAN system will be reliable and a benefit to the machine builder and the machine operator.

"CAN" J-1939?

CAN protocol was developed by Bosch in the early 1980s. CAN stands for Controlled Area Network. By definition, CAN networks have microprocessor based units that can communicate with each other over the same pair of wires. CAN J-1939 was developed to provide a 250 K Baud CAN system for use on heavy trucks and off-highway vehicles. The first SAE J-1939 standards were released in 1994- over five years ago.

J-1939 DESIGN

CAN J-1939 was designed to be used two ways: for truck and bus applications, the communication media is a shielded twisted pair with a drain that requires a termination resistor at each end (CAN_H and CAN_H); for construction/agricultural, applications the communication media that is a twisted non-shielded quad (CAN_H, CAN_L, CAN_BAT, and CAN_GND).

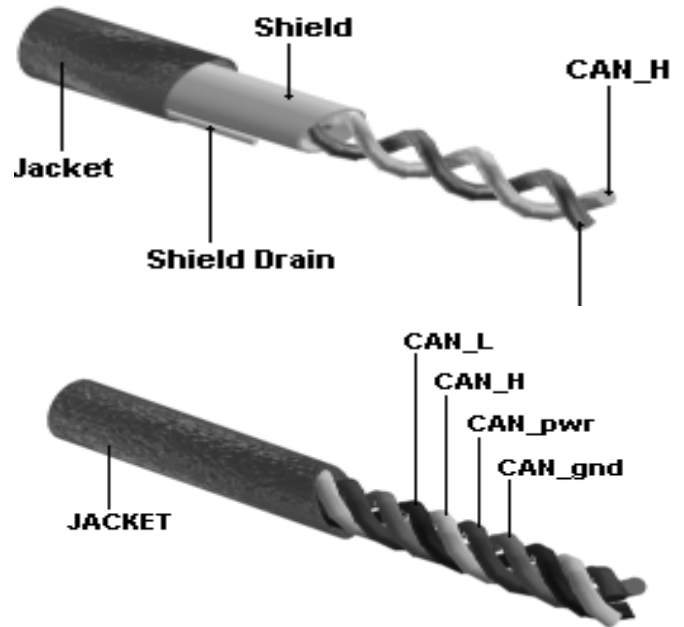

Fig. 1, CAN cables.

The 110 ohm termination resistors and twisting of the data pair make the data communication pair very EMI/RFI tolerant. The use of the CAN_H and CAN_L concept for the communication pair also contributes to the robustness of the communication scheme.

J-1939 also contains a message priority identifier in the first three bits of the 29 bit identifier field. A message of 000 is the highest priority. This priority feature allows the higher priority messages to displace "maintenance" messages. The J1939 protocol also includes collision detection and arbitration (CSMA/CD Carrier Sense, Multiple Access with Collision Detection).

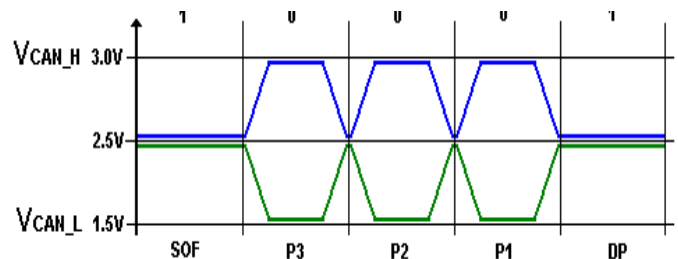

Fig 2, CAN pair showing 0 and 1 states with maximum priority of "000".

With J-1939 there are five types of error detection:

- Bit error- bit received is not the value transmitted
- Stuff error- more than five consecutive bits of the same polarity
- CRC error- CRC is sent with data and is compared to calculated CRC
- Form error- fixed format fields are violated
- ACK error- no ACK is sent by receivers

Fault confinement is embedded through the use of transmit and receive error counters.

SAE J-1939 has sufficient capacity to handle navigation systems, radar or GPS. CAN 2.0B which has the added 29 bit identifier is the standard adopted for J-1939.

J-1939 systems are limited to 30 nodes per segment with a maximum backbone length of 40 meters per segment. The ECU stub must be less than 1 meter in length.

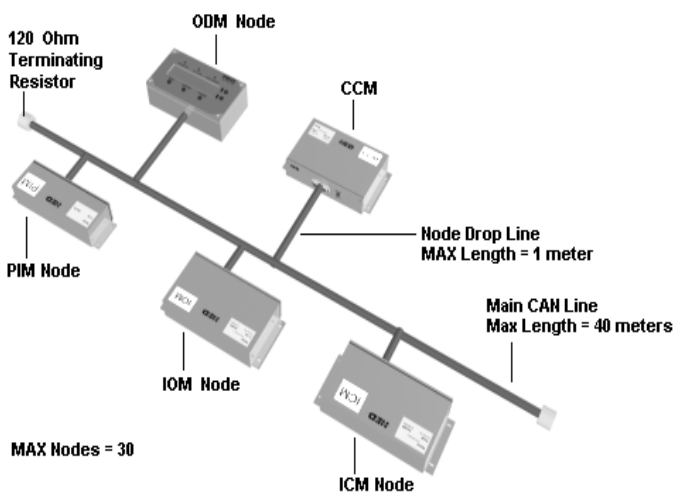

Fig. 3, J-1939 system layout.

“REGISTERED” VERSUS “PROPRIETARY” J-1939

“Registered” addresses are described in SAE J-1939/71 VEHICLE APPLICATION LAYER and SAE J-1587 JOINT SAE/TMC ELECTRONIC DATA INTERCHANGE BETWEEN MICROCOMPUTER SYSTEMS IN HEAVY-DUTY VEHICLE APPLICATIONS. These addresses are the same for all systems. Many items on specific purpose heavy duty trucks and most Off-Highway vehicles have requirements not met by the “Registered” addresses. To address these requirements, the use of “Proprietary” addresses is adopted. To avoid conflict, it is strongly suggested that “Registered” and “Proprietary” codes not be used on the same segment.

Vehicles with both types of code can be accommodated through the use of dual CAN systems. One system talks only to the “Registered” code nodes and the other system talks only to the “Proprietary” code nodes. Several J-1939 CAN system manufacturers currently offer Bridges and/or ECUs that contain two J-1939 loops controlled by microprocessors that translate between the two types of addresses.

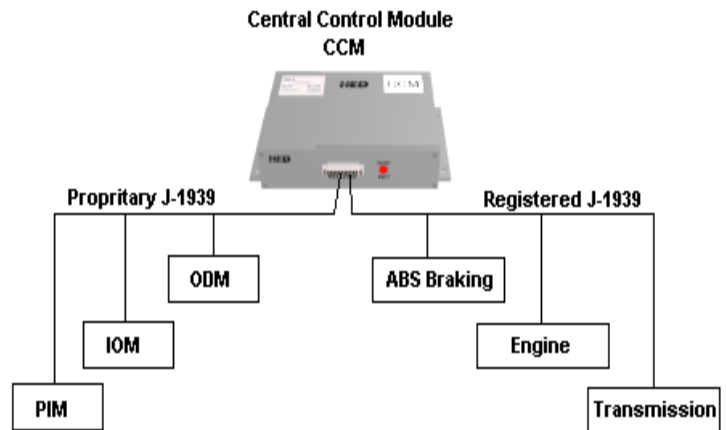

Fig 4, ECU with Registered and Proprietary capability.

OTHER INTERFACES, ETC.

CAN KINGDOM- is supported by the European based CAN Hydraulic Users Group. This variety of CAN is considered to be a set of protocol primitives that are customized by each user. CAN Kingdom reportedly allows J-1939, Devicenet, and SDS on the same backbone.

CAN 2.0B- is formatted the same as J-1939 with a 29 bit identifier. Version B is backward compatible with J1850 and CAN 1.2. CAN 2.0B is run at speeds up to 1,000 kbps.

There are also supplier specific CAN systems such as Sauer-Sunstrand’s S-Net. These are designed to work with a specific manufacturer’s components. While this approach can be quite efficient for that manufacturer, addition of components from a different manufacturer is very difficult.

TYPICAL APPLICATIONS

The J-1939 specification is initially being applied in volume on trucks. The system is being used for engine, transmission, and ABS brake coordination. There is also a number of applications being introduced for Tractor to Trailer communications.

Fire and rescue apparatus applications are a particularly appropriate application. The number of wires exiting a fire truck cab number in the hundreds. These wires can

be eliminated through the use of J-1939. The wiring cost reduction and the reduction of trouble shooting time at the end of the line will pay for the cost of the J-1939 system. The additional capabilities of the J-1939 system adds significant benefits for the manufacturer, dealer, and truck owner.

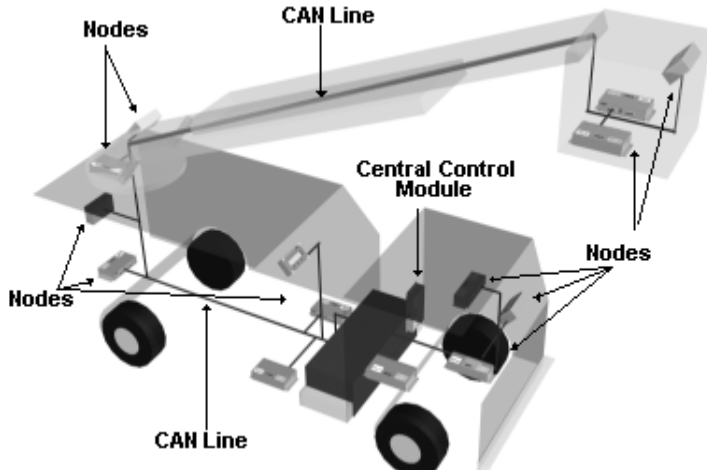

Fig 6, Typical Fire Aerial Ladder Application.

Another application is the aerial work platform market. Operator stations both in the platform and on the ground as well as operation of the engine below rotation along with outriggers, etc. allows the CAN J-1939 system to reduce cost while improving operation characteristics. The use of the CAN based system allows increased safety interlocks and monitoring of machine abuse. A number of time registers can be used to provide innovative leasing and rental.

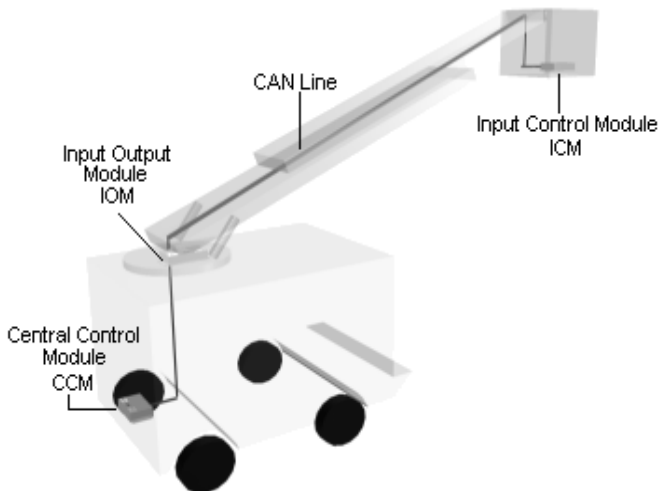

Fig 7, Aerial Work Platform Application.

Road building equipment is quite often offered in a multitude of variations as many options are added to the base machine. The use of J-1939 allows the pre-wiring of CAN and power for options and the addition of CAN modules as need to implement the options. Often the software for all of the options will exist on the machine so that field additions do not require reprogramming.

The use of node (module) identification through use of identification pins in the wiring harness activates the required software. Thus the modules can be the same part number and yet have different functions for specific locations.

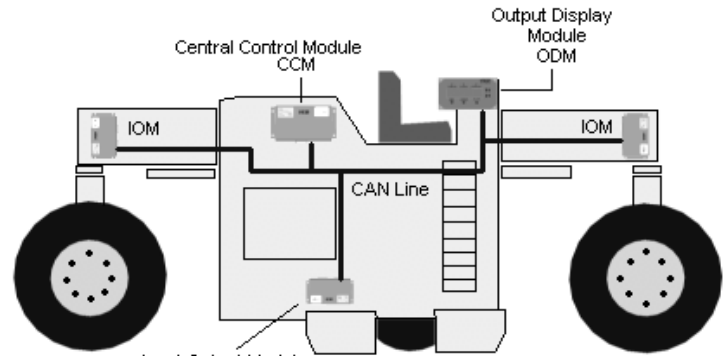

Fig 8, Road Building Machine.

Machines that maintain railroad tracks and beds require communications between cars as well as within the special purpose car. The number of nodes on a given car may be relatively low. However when the full work train is connected so that control of each car is coordinated with the main engine, the number of nodes can be quite significant. The use of J-1939 allows cars to be added or dropped easily with automatic recognition of the trains new content.

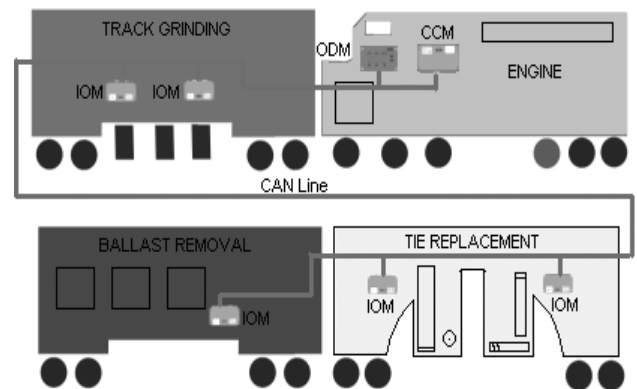

Fig 9, Railroad Maintenance Machine.

WHEN TO CAN AND WHEN TO CAN CAN

Today the hottest buzz word in Mobile Electrohydraulics is CAN. CAN is being considered in design where there is only a small advantage to using CAN at the best. If the number of nodes is three or less, consider other digital communication methods such as serial communication over a RS 232 or other system. If there will be a small number of systems built, the software development may not be justified. A typical example a low number of nodes is a crane with a LMI (Load Moment Indicator) where the LMI computer is mounted on the crane boom and the display is mounted on the

truck chassis mounted operator's platform. The crane is a 380 degree design so that there were not any electrical slip rings. (If there were slip rings, the CAN system would provide superior signal transmission and a robust

transmission error detection and checking.) An example of a project with a small number of machines would be a special purpose pipe handler that required 4 nodes but only two machines.

WHERE IS CAN TODAY?

Because of the flexibility provided by "Proprietary" J-1939 it is the CAN of choice for Off-Highway machines for construction, material handling, forestry, etc. Owner/operators as well as rental yards appreciate the additional features added to machines at a very nominal cost.

The Heavy Duty On-Highway trucks are applying J1939 to communications in the Tractor as well as for communication with the trailer(s) where J-1939 is required for some ABS on trailers. Currently, J-1939 is moving downward to Medium Duty trucks used to mount equipment such as "Pin-on-Cranes", etc.

SAE J-1939 is the basis of several of the better recognized CAN communication protocols of large machinery manufacturers. Both the protocol sometimes referred to as "CAT CAN" and the protocol used by John Deere are like J-1939. Though, there is some discussion as to which came first.

J-1939 is currently 250 kbps with several companies looking at the feasibility of speeds up to 1,000 kbps for distances up to 40 meters.

There has been little work to place CAN transmitting sensors on the CAN backbone because they often cost up to ten times more than existing analog sensors. Many of the sensor manufacturers have programs to change this over the next few years. Until then, sensors will be wired to nodes that will have a number of sensor inputs as well as other functions. Most CAN transmitting sensors available today are either to allow the manufacturer to say "We make CAN compatible sensors." Or, they are for market testing.

MAKING J-1939 SYSTEMS SURVIVE IN THE REAL WORLD OF OFF-HIGHWAY EQUIPMENT.

The J-1939 backbone cable is probably the most reliable part of the machine. Because of the low design impedance, the high signal voltage levels, and the twisted pair, J-1939 is not very susceptible to interference from EMI/RFI.

Emissions from the CAN cable, however, are another matter. If the nodes are allowed to transmit messages

with essentially vertical rise and fall of the pulse, the cable will perform as an efficient emitter. Addition of slew resistors to the transmit circuit will result in a modification to a trapezoidal waveform that has a much lower rise rate and thus much less RF emission from the CAN cable.

Reverse voltage protection on the power input should be 1,000 volts with the same protection for each of the sourcing output drivers. This is needed to withstand Back EMF resulting from other components on the vehicle.

The module should be capable of surviving at least 60 VDC for 2 minutes at 25°C to withstand cold weather jump-starts.

The minimum operating voltage range is 9 to 32 VDC

0 to 5 VDC analog signal inputs should be capable of withstanding direct shorts to the battery. Digital inputs should be protected if connected to either + battery or - battery.

Outputs should be protected against shorts to + battery and - battery.

Negative spike protection to 1,000 VDC should be provided on all outputs.

For ease of field trouble shooting and training non-electronic personnel, stick with sourcing outputs. While slightly higher cost, you will save far more dollars by not having to try to explain sinking outputs to someone over the telephone. Everyone can relate to the fact that if the trouble light is lit, the output is on. Most people have great difficulty in understanding that if the trouble light at the output is on, the output is off and if the light is off, the output is on.

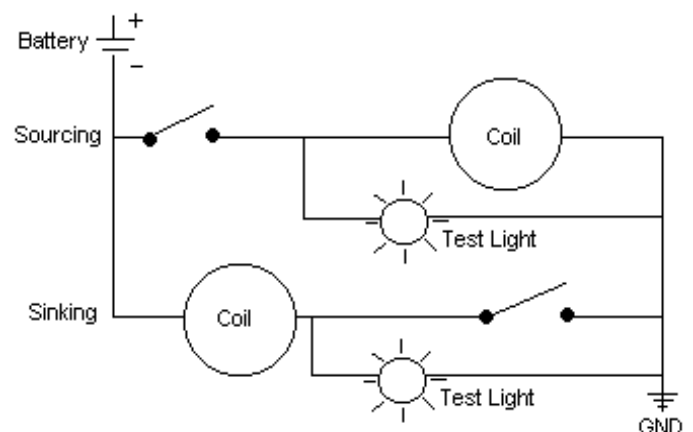

Fig 10, Sourcing and Sinking Circuits.

While modules that operate in the temperature range of -40°C to +85°C with storage of -55°C to +100°C are commonly available, the displays have a restricted temperature range. The display electronics will operate

in the same temperatures as any other modules. The actual display will be significantly restricted. Most manufacturers will add heaters to allow cold operation of the display. Only a few manufacturers will add Peltier Effect cooling modules to the display to provide higher operation temperatures. Without the cooling modules, the displays are limited to +50°C to +70°C maximums, depending on make. Addition of the Peltier Effect modules significantly increases the cost of the display assembly.

WHAT DOES CAN J-1939 MEAN TO YOU

To the designer, J-1939 offers a proven fault tolerant communication system that has the ability to incorporate modules from different manufacturers. Most module manufacturers have already developed the embedded code needed to have the inputs and outputs “do their thing”. For example, an output can be driven to operate as a PWM (Pulse Width Modulation) output with sophisticated control curves to limit “Jerk” (the derivative of acceleration) on swing applications. The designer may also have available to him software modules to use in creating the application specific software for his specific machine. As each CAN module manufacturer works on more and more different machines, more application software is placed in the module manufacturer’s library.

As much as the designer may think that CAN J-1939 was created for him, the real winner at the equipment manufacturer is the manufacturing department. The same module can be used in many places on many different models. The common module takes on individual characteristics when pin identification is used. Pin identification is the use of on-off input pins wired to either battery or ground to tell the module what software it should use to operate in that particular position. The number of different identifiable positions is limited by the number of input pins available. The number of different identifications is 2 to the power of the number of available pins, less 1. Thus, eight pins yields 255 different positions.

After the manufacturing manager gets over “one module does almost everything”, he can chalk up the savings resulting from the ease of installation. No longer must several hundred wires be pulled the length of the machine. In most cases, all but the CAN pair, power, and ground wires can be kept to an arm’s length.

The heartbeat LED on the modules assures the trouble shooter that the module has power and is alive. A computer connected to the network can turn on or off any output and read the status of any input for trouble shooting. After determining that he is turning on the correct light, actual wiring trouble shooting is greatly simplified. The technician or assembler can trace the short wire easily and check with a trouble light to be sure that power is in fact being supplied to the light socket as

well as the output pin of the module. If there is power at the output pin and not at the light socket, replacing the wire is easy.

The machine testing part of manufacturing can be much simpler. The tester can actuate the inputs in order and the test computer connected to the CAN system can identify any failures or incorrect wiring. The computer then can activate each of the outputs and the tester can check to be sure that the function works.

The Machine owner/operator wins big. The machine can have significantly increased automation and smarts. The computer used for CAN transmission will protect the machine from abuse and will notify the operator of required service intervals. The computer can notify the operator of faulty sensors and output devices.

The field service technician will love a CAN system. He can connect a laptop computer or service tool to the CAN network and download a history of any faults or overlooked suggested maintenance.

To assist the designer and the warranty department, the system can log any number of items such as when the machine was loaded to 90% of capacity, 100% of capacity, and overloaded. The system can record not only the total hours; but, also the time and date they occurred. This information can be password protected for reading or resetting. Upgrades can be downloaded through the same laptop connection.

Changes to settings such as motor speed can be modified to different degrees through the use of Passwords. For example, the operator may be allowed to reduce motor speed but not increase it beyond the factory setting. The dealer may be allowed to increase the motor speed by a maximum of 10 percent. The factory service representative may be allowed to increase the factory setting by 20 percent using a different password. The design engineer using yet another password may have no limits place on him.

WHERE IS CAN J-1939 GOING TOMORROW?

- The data rate of 250 kbps may increase up to or exceed 1 mbps. The real question is if the increase can be done in such a manner as to allow use of the higher speed units with existing J-1939 components.
- More and more “Registered” codes will appear. These will be needed to accommodate the newer power sources and innovative sensors.
- Most Off Highway machines will be predominately “Proprietary” code based and will communicate with drive trains that are “Registered” code.

- Fiber optic versions of J-1939 CAN will appear on production modules. This communication mode will be used for applications in severe EMI/RFI environments or where emissions must be kept to near zero such as Military equipment.
- There will be a tendency to become “feature drunk”. Because the addition of features on machines that already have the sensors and the computing power is so low cost, designers will over indulge. Some machines will reach the point that the operators will not use all of the features offered because it will take too long to learn how to use the features. [This is very similar to what is happening now with some of the office software suites shipped with today's computers. “All the buyer wanted was to type a letter; not, create a linked e-mail file.”]
- Developing a CAN J-1939 application is fairly involved and somewhat expensive today. In particular, developing the application code is time consuming and tedious. This will become less burdensome as the tools become simpler and development engineers become more comfortable with the process of describing the desired machine operation. Today, the machine normally is very expensive or there has to be a large number of machines to justify the development cost of implementing CAN J-1939. Over the next several years, the machine cost and the minimum economical quantity to apply CAN J-1939 will decrease.
- An example how technology changes: twenty years ago, the feeling in the construction equipment market was that pilot pressure regulator controlled valves would only appear on the most expensive, high duty machines such as the largest excavators. Today, Pilot Pressure Control (PPC) valves appear on machines so small that several of them can be placed in the bucket of the first PPC machines. CAN controls will follow the same path.
- CAN system cost per machine will be reduced as the manufacturers develop more and more specific purpose modules with the exact input and output counts needed. The specific purpose modules developed for the larger users will trickle down to the smaller quantity users and reduce their costs.
- With every technological innovation comes the “left handed monkey wrench”. The authors recently became aware of a pressure switch that claimed to be settable via CAN. In order to be settable via CAN, the unit had to be a pressure transducer with a processor that memorized the value commanded via the CAN network. If you have a sensor with an analog output, use it as an analog output and get the

- real time reading, not just when the set pressure is passed.

CONCLUSION

It has taken four years since the publication of the first J-1939 specification for there to be a significant production of J-1939 based machines. Or, any CAN based mobile machines. Since the first major applications, many designers are evaluating CAN J-1939. They are applying many of the features available:

- Robust design
- Increased reliability
- Self diagnostics
- Ease of installation
- Elimination of long connection wires
- Log and record capabilities
- Time and date logging
- Down loading to a laptop computer
- Remote query
- Remote upgrading of software
- Protected safety interlocks
- EMI/RFI tolerant
- High benefit to cost ratio

The application to production machines will accelerate to the point that CAN will be the predominate communication mode for multi-module machines.

Newer design machines will use the multi-module design in place of the older one control device approach.

The applications currently using SAE J-1939 are only the tip of the iceberg compared to the number of applications that will be moved to production over the next five years.

It's great to be in the CAN business.

Definitions, Acronyms, Abbreviations

ABS- Anti-skid Braking System

Back EMF- a negative spike created on a supply line when an electrical load is disconnected.

Backbone- the main CAN connection line

Baud- one bit of data

CAN- Controller Area Network

CAN Kingdom- A CAN protocol used in Europe

Devicenet- A CAN protocol

ECU- Electronic Control Unit

EMF- Electro Motive Force

EMI/RFI- Electro Magnetic Interference/ Radio Frequency Interference

GPS-Global Positioning System

Kbps- Kilo baud per second

Modules- CAN transmitter/receiver units that may also have inputs and outputs

Node- The connection point for modules

Password- a specific alpha-numeric sequence that is recognized by the computer to allow certain functions

Pin-on cranes- cranes designed to be mounted on standard truck chassis

SDS- CAN protocol

Sinking- a method of electrical control where the switching device connects or disconnects the circuit to ground

Sourcing- a method of electrical control where the switching device connects or disconnects the circuit to battery

