

CL-609 Product Family Specification

PFS-CL609

5/28/2015



INTELLIGENT VEHICLE CONTROLS



HED® Inc.

2120 Constitution Avenue

Hartford, WI 53027 USA

Telephone: (800) 398-2224

Fax: (262) 673-9455

Email: info@hedonline.com

Web: www.hedonline.com

Copyright 2015 © HED® Inc.

All rights reserved. This material may not be reproduced, published, displayed, modified, or distributed in any form or by any means, or stored in a database retrieval system, without the express prior written permission of HED® Inc.

USING THIS DOCUMENT

The specifications contained herein represent all possible configurations for this product family. The actual configurations available on each module may be a subset of this specification. Please refer to the module-specific datasheet for the connector pinout and configurations that are available.

USER LIABILITY

The OEM of a machine or vehicle in which HED® electronic controls are installed is fully responsible for all consequences that might occur. HED®, and any authorized distributor, has no responsibility for any consequences, direct or indirect, caused by failures or malfunctions. Failure or improper selection or improper use of HED® products can cause death, personal injury and property damage.

The OEM must analyze all aspects of their application and review the information concerning product or system in the current product documentation. Due to the variety of operating conditions and applications for these products or systems, the user, through its own analysis and testing, is solely responsible for making the final selection of the products and systems and assuring that all performance, safety and warning requirements of the application are met.

The products described herein, including without limitation, product features, specifications, designs, availability and pricing, are subject to change by HED® at any time without notice.

INPUT STB/STG/VTD (PIN B01)

INPUT STB/STG (PIN B02)

Switch-to-Battery (STB) Mode¹

- Input Resistance
- 1.4K Ω (typical)
- Input Current
- 5.7mA at 8V (typ)
 - 24.0mA at 32V (typ)
- Positive Going Threshold
- > 6.5V
- Negative Going Threshold
- < 3.5V
- Parallel Resistance
- 2K Ω at 8V (minimum)
 - 12K Ω at 32V (minimum)
- Series Resistance
- 220 Ω (maximum)

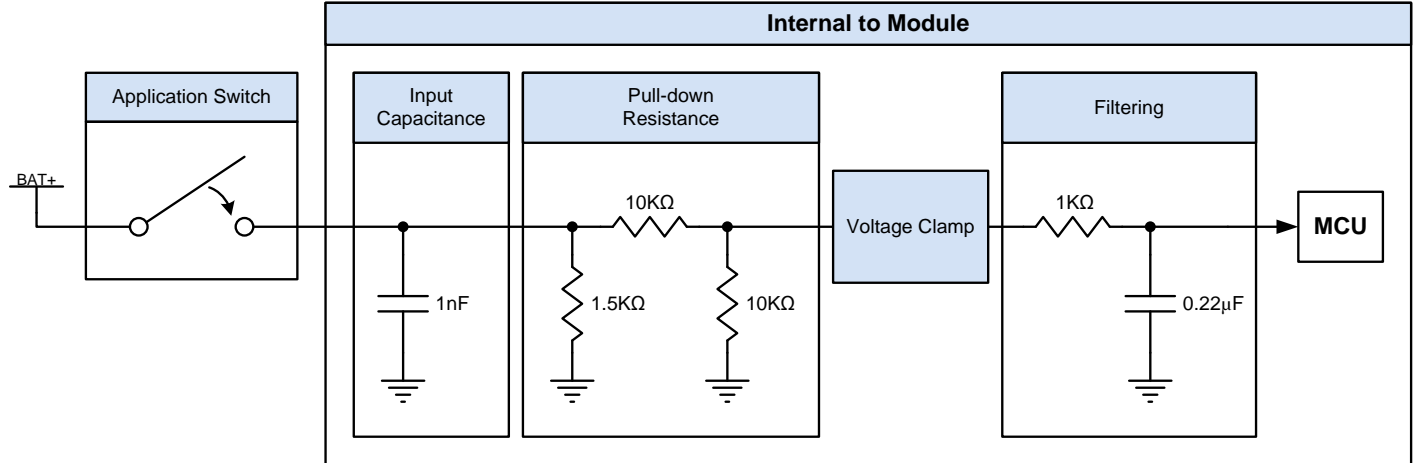

Switch-to-Ground (STG) Mode²

- Pull-up Resistance
- 560 Ω (typical)
- Input Current
- 7.6mA at 0V (typical)
- Positive Going Threshold
- > 3.25V
- Negative Going Threshold
- < 1.75V
- Parallel Resistance
- 2K Ω at 0V (minimum)
- Series Resistance
- 220 Ω (maximum)

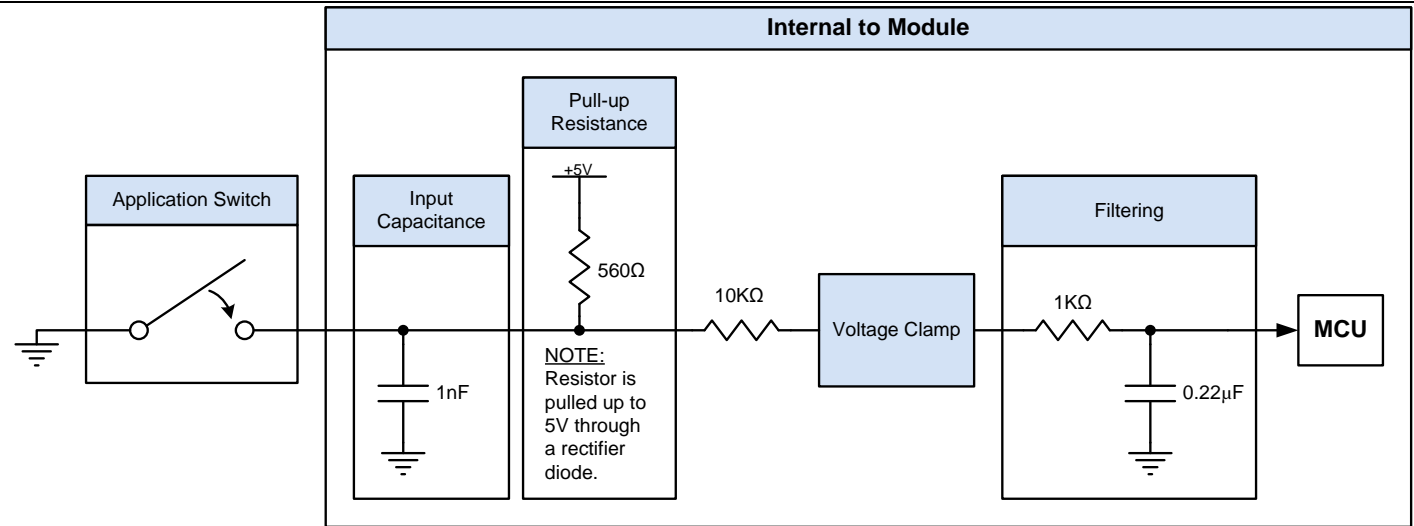

¹ Pin B01 has a voltage divider in STB Mode of 68.1K Ω /68.1K Ω instead of 10K Ω /10K Ω , resulting in approximately 5% to 10% reduction of input current.

² Pin B01 has a series resistance in STG Mode of 68.1K Ω instead of 10K Ω .

INPUT STB/STG/VTD (PIN B01)

Voltage-to-Digital (VTD) Mode (0 – 36.37VDC)

Input Voltage Range

- 0V to 35.45V (minimum)
- 0V to 36.37V (typical)

Input Resistance

- 78.1K Ω (typical)

Resolution

- 12 Bits
- 8.88mV / count (typical)

Accuracy²

- $\pm 2.3\%$ and $\pm 69\text{mV}$ ($T_A = 25^\circ\text{C}$)
- $\pm 4.4\%$ and $\pm 103\text{mV}$ ($T_A = \text{Full}$)

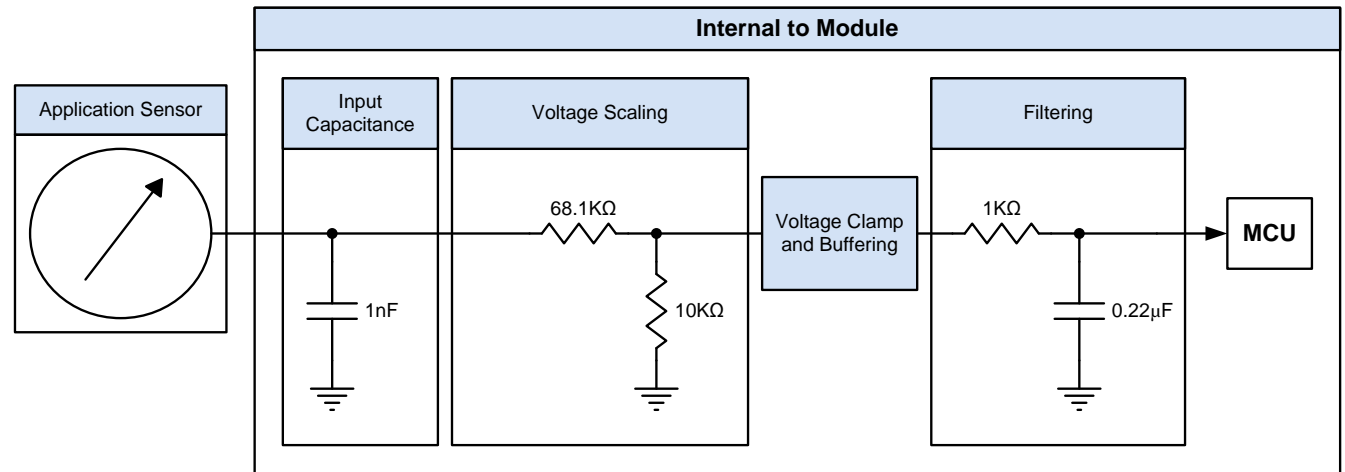

CAN COMMUNICATION (PINS A03/A04)

Baud Rate

- 40kbps to 500kbps

Maximum Allowable Voltage¹

- -27V to +40V

Input Capacitance (maximum)

- 26pF (f = 1MHz)

No Internal Termination

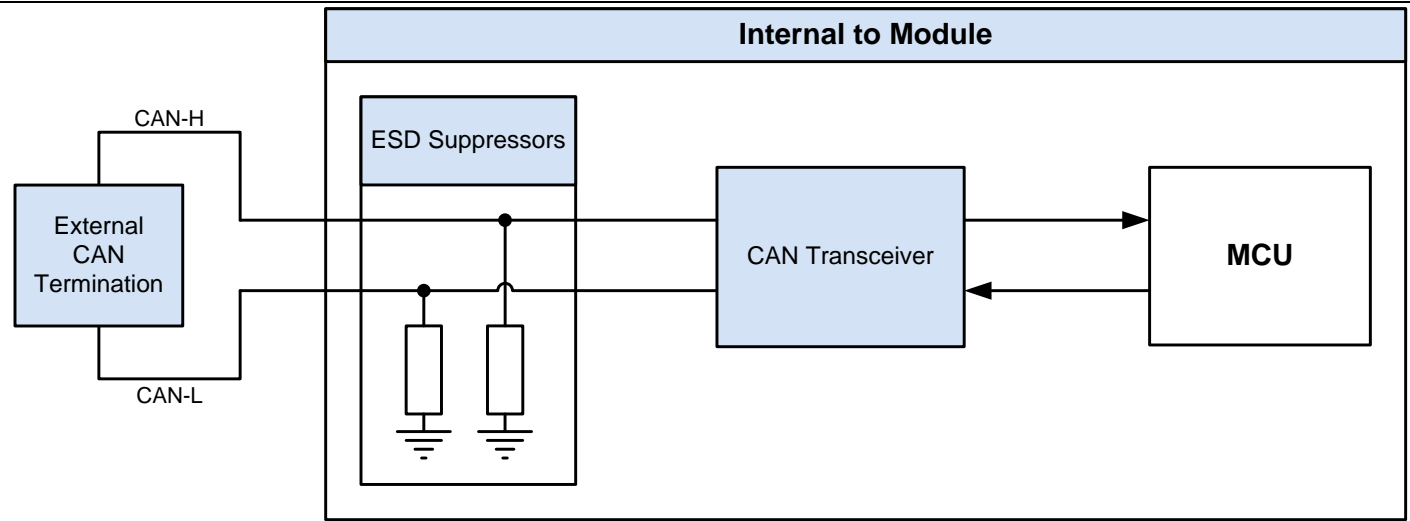

¹ Maximum allowable voltage defines the voltage extremes that the transceiver can tolerate. Exposure to these voltages for extended periods may affect device reliability.

BACKLIGHT AND INDICATOR LEDs

Backlight LEDs		Indicator LEDs	
Color	Dominant Wavelength (typical)	Color	Dominant Wavelength (typical)
Yellow	589 nm	Green	525 nm
Blue	465 nm	Yellow	590 nm
Green	525 nm	Orange	601 nm
White	Chromaticity: Cx = 0.31, Cy = 0.31	Blue	465 nm
		Red	630 nm

OUTPUT DOUT(-)/PWM(-) (PINS B01-B04)

Output Current

- 750mA (maximum)

PWM Frequency

- < 300 Hz (typical)
- < 1 KHz (maximum)

Output Protection

- Short to Battery
- Short to Ground
- Open Circuit

Output Diagnostics

- None

Hardware Current Limit

- 7.5A (typical)

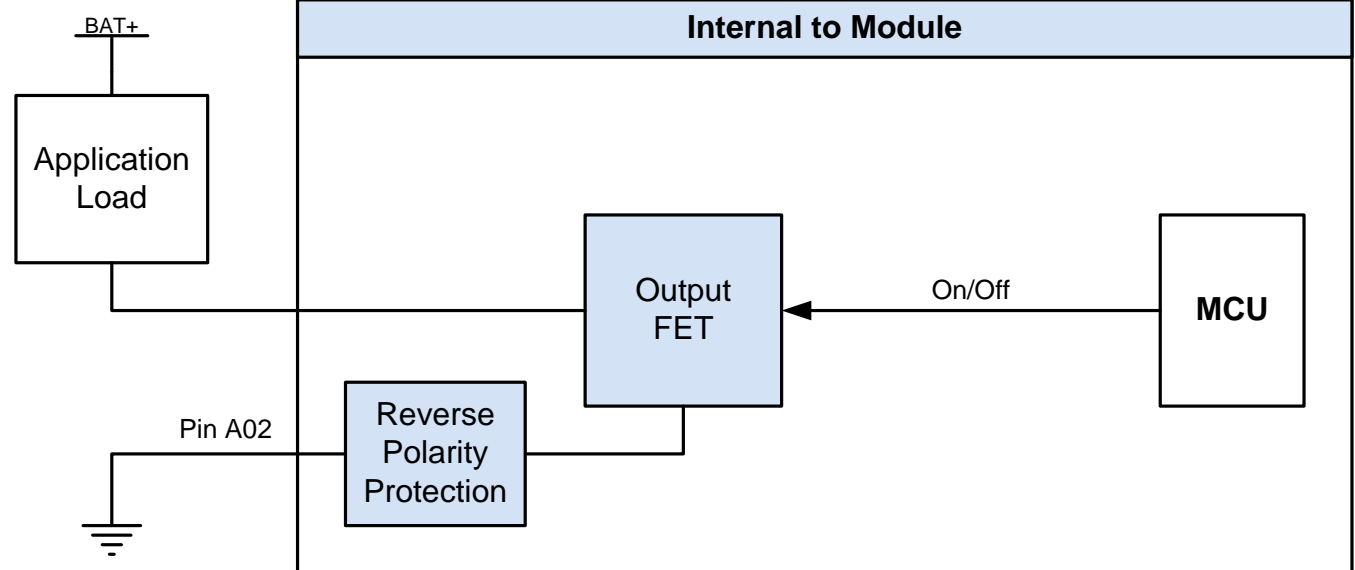

BATTERY (+) MODULE (PIN A01)¹

Battery (+)

Operating Voltage Range

- 8VDC – 32VDC

Maximum Continuous Voltage²

- 36VDC

Module Current Draw³

- 32mA at 8.0V (typ)
- 22mA at 13.8V (typ)
- 17mA at 28.0V (typ)
- 16mA at 32.0V (typ)

Module Current Draw⁴

- 132mA at 8.0V (typ)
- 76mA at 13.8V (typ)
- 43mA at 28.0V (typ)
- 40mA at 32.0V (typ)

Analog Monitoring Circuit

Input Voltage Range

- 0V to 35.45V (minimum)
- 0V to 36.37V (typical)

Input Resistance

- 78.1K Ω (typical)

Resolution

- 12 Bits
- 8.88mV / count (typical)

Accuracy²

- $\pm 2.2\%$ and $\pm 37\text{mV}$ ($T_A = 25^\circ\text{C}$)
- $\pm 4.4\%$ and $\pm 458\text{mV}$ ($T_A = \text{Full}$)

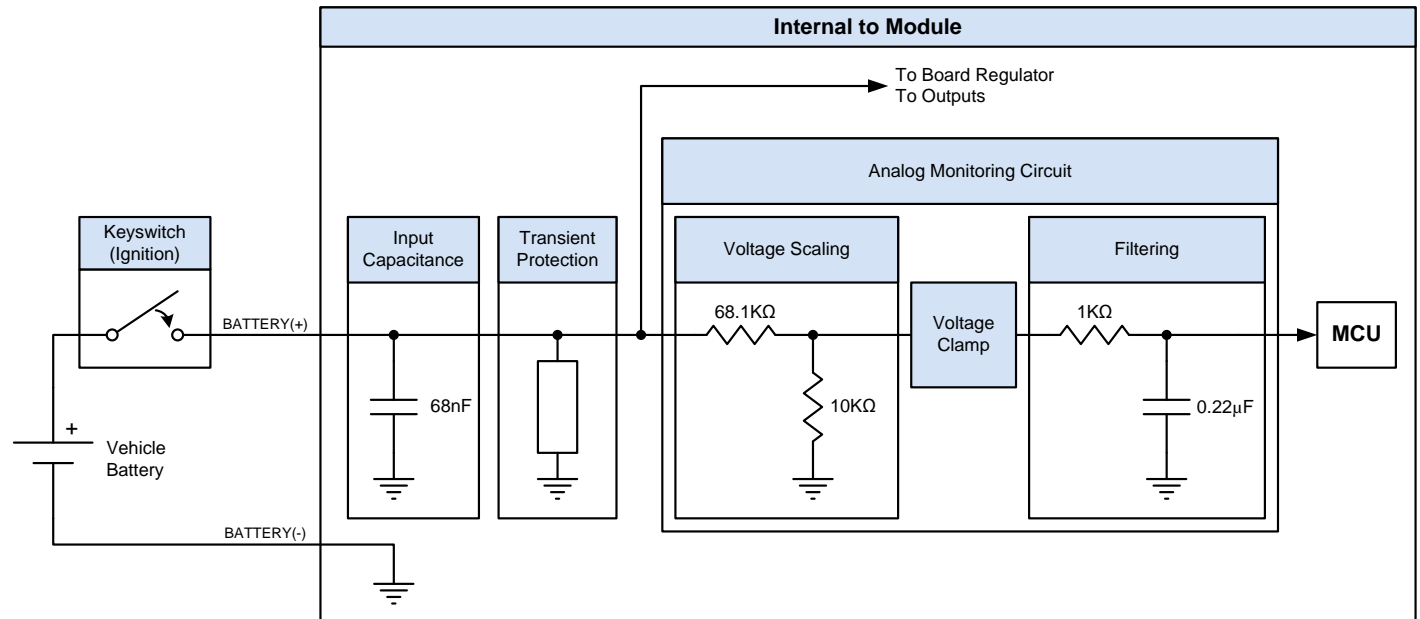

¹ The block diagram shown represents one possible implementation in the system. Other implementations may be used based on system requirements.

² Exposure to maximum voltages for extended periods may affect device reliability.

³ Module current draw is measured with I/O inactive, no CAN communication, and all LEDs (indicator / backlight) off.

⁴ Module current draw is measured with I/O inactive, no CAN communication, and all LEDs (indicator / backlight) on.

REVISION HISTORY

Revision	Date	EC #	Changes
A1	5/28/15	315-067	Initial Release.